



GENERAL

ALIAEMT The ARH950 Series Wall / Duct mount Relative Humidity Transmitter is the most versatile transmitter in the market. ARH950 combines high accuracy, stability and reliable operation, making these products the ideal choice for demanding applications.

FEATURES

- ❑ Two Line LED (LCD) display, directly read the RH & temperature
- ❑ Accuracy up to +/-2% RH
- ❑ DIP switch selectable signal input of Temperature
- ❑ 4 wires, 4-20 mA * 2 for both Humidity & Temperature output
- ❑ Small, light and easy to be installed
- ❑ Full 0-100% RH measurement
- ❑ RH 0.1%, Temperature 0.1 °C Resolution
- ❑ 8 Seconds fast response time

STANDARD SPECIFICATION

Measuring Range

Relative Humidity : 0-100% RH
Temperature : 0~50 / -20~80 / -40~60 °C

Accuracy

Relative Humidity : +/-2% RH@25 °C
Temperature : +/-0.3 °C@25 °C

Resolution

Relative Humidity : 0.1% RH
Temperature : 0.1 °C

● Repeatability : +/-0.1% Typical

● Humidity Drift : <0.5% RH / Year

● Temperature Drift : <0.1 °C / Year

● Operating Temperature : -20~70 °C

● Storage Temperature : -10~60 °C

● Storage Humidity : 0-90% RH

Material

Electrical Housing : ABS (Duct) / PC (Wall)
Aluminum Alloy (Duct, IP65)
Probe : ABS (Duct), S.S. 316 (Duct, IP65)
Flange : PC (Polycarbonate)
Sensor Housing : PC (Polycarbonate)

Protection Class

Duct Mount : IP54 / IP65
Wall Mount : IP44



- Display : RH: 0.0-99.9% LED (LCD)
: Temperature: +/-99.9 °C
- Output
Relative Humidity : 4-20 mA
Temperature : 4-20 mA
Load : Rohm= (VDC-15) * 50
- Response Time : 8 Seconds
- Turn on Time : 3 Seconds
- Power Supply : 15-36 VDC
- Power Consumption : <50 mA@24 VDC
- Electrical Connections : D Type: PG9, P Type: M20
: Screw Terminal Block (Wall Mount)
- Screw Terminal : 0.5-1.5 mm²
- Dimensions
Duct Mount : 85 mm (L) * 85 mm (W) * 241.4 mm (H)
100 mm (L) * 100 mm (W) * 278.4 mm (H)
Wall Mount : 100 mm (L) * 84 mm (W) * 23 mm (D)
- Weight
ARH950-D : 146 g
ARH950-W : 83 g
ARH950-P : 810 g
- EMI / RFI Effect : Follow SAMA PMC 33.1 from 20-1000
MHz and for field strengths up to 30 V/m
- Vibration Effect : +/-0.1% of Full Scale Per g to 200 Hz in
any axis



➤ DIMENSIONS

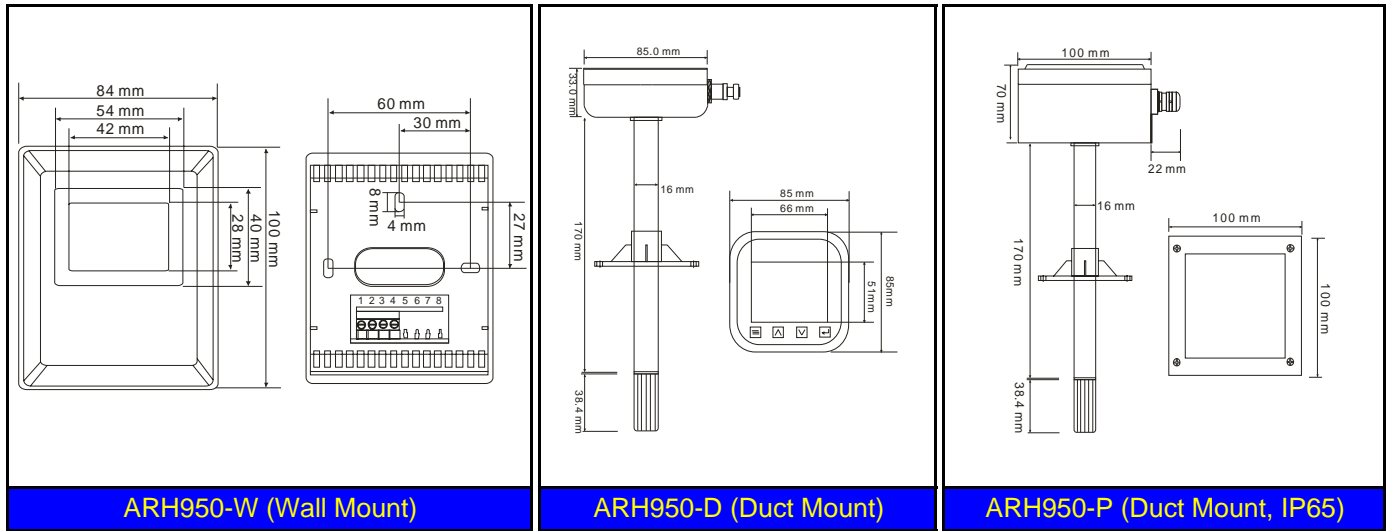

➤ WIRING DIAGRAM

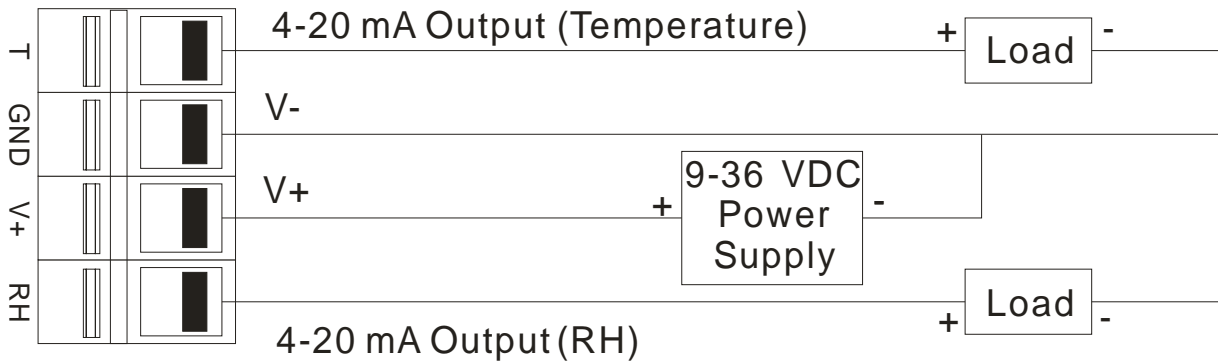

➤ MODEL SELECTION GUIDE

ARH950 Series					
Example: ARH950-DN1-N					
ARH950-	X	X	X	-X	Description
Installation	W				Wall Mount
	D				Duct Mount
	P				Duct Mount, IP65, Aluminum Housing, Stainless steel 316 Tube, ** IP65 without Display
Display	N				None
	D				Two Line LED (LCD), 3 Digit Temperature, 3 Digit Humidity (Only for Installation D & W)
Temperature Range		1			0~50 °C
			2		-20~80 °C
				3	-40~60 °C
Option				-N	Standard
				-S	Remote with 10 m cable (Only for Installation code: D=Duct Mount)